



# MyPower S3400 Series Carrier-class Switch Datasheet

---

*Maipu Communication Technology Co., Ltd*  
No. 16, Jiuxing Avenue  
Hi-tech Park  
Chengdu, Sichuan Province  
People's Republic of China - 610041  
**Tel:** (86) 28-85148850, 85148041  
**Fax:** (86) 28-85148948, 85148139  
**URL:** [http:// www.maipu.com](http://www.maipu.com)  
**Email:** [overseas@maipu.com](mailto:overseas@maipu.com)

All rights reserved. Printed in the People's Republic of China.

No part of this document may be reproduced, transmitted, transcribed, stored in a retrieval system, or translated into any language or computer language, in any form or by any means, electronic, mechanical, magnetic, optical, chemical, manual or otherwise without the prior written consent of Maipu Communication Technology Co., Ltd.

Maipu makes no representations or warranties with respect to this document contents and specifically disclaims any implied warranties of merchantability or fitness for any specific purpose. Further, Maipu reserves the right to revise this document and to make changes from time to time in its content without being obligated to notify any person of such revisions or changes.

Maipu values and appreciates comments you may have concerning our products or this document. Please address comments to:

*Maipu Communication Technology Co., Ltd*  
No. 16, Jiuxing Avenue  
Hi-tech Park  
Chengdu, Sichuan Province  
People's Republic of China - 610041  
**Tel:** (86) 28-85148850, 85148041  
**Fax:** (86) 28-85148948, 85148139  
**URL:** [http:// www.maipu.com](http://www.maipu.com)  
**Email:** [overseas@maipu.com](mailto:overseas@maipu.com)

All other products or services mentioned herein may be registered trademarks, trademarks, or service marks of their respective manufacturers, companies, or organizations.

---

# Contents

---

<b>MyPower S3400 Series Carrier-class Switch .....</b>	<b>4</b>
<b>Key Features.....</b>	<b>5</b>
<b>Product Features .....</b>	<b>6</b>
<b>Technical Specifications .....</b>	<b>8</b>
<b>Order Information.....</b>	<b>11</b>
<b>Typical Applications .....</b>	<b>14</b>
MAN Access and Aggregation.....	14
IP Unified Bearing Multiple Services of Base Station .....	14
Business Building Access .....	15
L2 VPN Service .....	16
L3 VPN Service .....	16

# MyPower S3400 Series Carrier-class Switch

---

MyPower S3400 series switch provides carrier-class Ethernet access switches for operators. It supports next generation L2 and L3 features and meets the requirements of customers for QoS, OAM, VPN, Multi-service and Protection.

S3400 can help customers develop IPTV, VoIP, VPN, wireless access and TDMoIP services. The high integrated platform design meets the requirement of the customer that a box provides rich physical interface and software features to reduce the total cost (TCO) and operating expenses (OpEx).

MyPower S3400 is the first in the world to adopt dual power supply, high integrated E1/T1 interface, standard PoE, and optical-electric Ethernet access on the access device. The operators adopt it to be deployed in 2G/3G base station for developing multi-service access (wireless, VPN, and mobile) and completing the reconstruction from TDM to IP.

MyPower S3400 series includes ten models and can meet the requirements of the operators' district access, base station access and business building access. It provides various VPN services. Each model can be configured with dual power supply. The S3400 that supports 10/100BASE-TX interface can be configured with PoE power supply module.



MyPower S3400 series

# Key Features

---

- MEF9&MEF14 Certifications
- Multi-service Ethernet switch with highest integrity
- Supports dual power supply
- Supports perfect OAM protocols(802.1ag,802.3ah,E-LMI)
- Supports VPN services defined by MEF9
- 50ms Ethernet service protection
- Supports VLAN Translation
- Supports QinQ and selective QinQ
- Supports UDLD and improves operation and maintenance capabilities
- Supports rich L2 and L3 protocols
- Supports PoE for IP Phone and wireless AP connection
- Supports PWE3 protocols for TDMoIP applications
- Supports perfect multicast protocol
- Hard QoS including two-rate three color mode(trTCM)

# Product Features

---

- **Multi-service access**

S3400 supports the PoE power supply of 8/16/24 Ethernet interfaces for accessing wireless AP; provides eight E1/T1 interfaces (TDMoIP) to meet the requirement that operators access 2G base station service to IP network through E1/T1 interfaces, and access the traditional TDM devices such as PBX, realizing unified IP bearing; supports Ethernet fiber access for operators to access commercial customers.

- **Perfect OAM**

Currently, S3400 is one of Ethernet access devices that support perfect OAM. It can help operators to manage the network more efficiently. In this way, the operation cost of customers is reduced. The supported OAM standards include 802.1ag, 802.3ah and E-LMI.

- **Various VPN**

S3400 passes MEF9 and MEF14 authentications of MEF, and supports the three VPN services including EPL, EVPL and E-LAN defined by MEF to help operators open various VPN services for customers.

- **Operator-level UNI/NNI**

Considering operators, S3400 defines all downstream interfaces as UNI interfaces. By default, UNI interfaces are disabled and have no local switching function. And the data on UNI interface is not sent to CPU, which ensures the device security. By default, NNI interfaces are enabled, which is convenient for operators to manage remotely.

- **50ms service protection**

S3400 adopts Ethernet ring protection technology of Maipu, which can realize 50ms network protection in single-ring, dual-ring/multi-ring, tangent-ring and crossover-ring networking environments. In this way, the service continuity of carriers is ensured and customer satisfaction is improved.

- **High reliability**

S3400 is one of the devices that are first to support power redundancy in 1U box. Each power can access different power supply networks. In this way, the hot backup for power modules (to prevent power supply fault) and the backup for power supply network (to prevent the power-off of power company) are realized.

- **Advanced QoS**

Each port of S3400 supports eight queues and the queue scheduling policies such as SP, RR, WRR, and WDRR; rich priority mappings including 802.1p→802.1p, 802.1p→COS, DSCP→802.1p, and DSCP→DSCP; 64Kbps-

based port traffic rate restriction and operators can limit the rate according to the time segment; Tail Drop and sRED packet loss arithmetic.

S3400 supports single-rate three-color mode (srTCM) and dual-rate three-color mode (trTCM) to meet the SLA requirements of operators, including CIR, CBS and PIR.

- **L2/L3 multicast**

S3400 supports 1024 concurrent multicast data flow; IGMP snooping and IGMP fast-adding/leaving protocol; L3 PIM and PIM-DM/SM protocol to meet the requirement of customers for multicast protocol.

- **Powerful anti-attack checking capability**

S3400 supports LAND, SYN Flood, Smurf, Ping Flood, Teardrop and Ping of Death and defines the processing policies for attack packets to ensure the device and network security.

- **Authentication mode**

S3400 supports 802.1x access authentication modes, and Radius and TACAS+ protocols to meet the requirements of operators' access authentication, authorization and accounting for customers.

# Technical Specifications

Item	Description
<b>Product configuration</b>	
<b>Product model</b>	<b>Interface</b>
SM3400-24FET4GEFA-AC	24 10/100M electric ports, four 1000M optical ports, two alarm input/output interfaces, one console port, one AC power supply
SM3400-24FET4GEFA-DC48	24 10/100M electric ports, four 1000M optical ports, two alarm input/output interfaces, one console port, one DC power supply (two power input interfaces are provided)
SM3400-24FET4GEF-AC	24 10/100M electric ports, four 1000M optical ports, one console port, one AC power supply
SM3400-24FET4GEF8E1-AC	24 10/100M electric ports, four 1000M optical ports, one console port, eight E1/T1 interfaces supporting PWE3, one 2M/25M clock input interface, one AC power supply
SM3400-24FET4GEF-DC48	24 10/100M electric ports, four 1000M optical ports, one console port, one DC power supply
SM3400-24FET4GEF8E1-DC48	24 10/100M electric ports, four 1000M optical ports, one console port, eight E1/T1 interfaces supporting PWE3, one 2M/25M clock input interface, one DC power supply
SM3400-8FET16FEF4GEF-AC	Eight 10/100M electric ports, 16 10/100M optical ports, four 1000M optical ports, one console port, one AC power supply
SM3400-8FET16FEF4GEF8E1-AC	Eight 10/100M electric ports, 16 10/100M optical ports, eight E1/T1 interfaces supporting PWE3, four 1000M optical ports, one console port, one 2M/25M clock input interface, one AC power supply
SM3400-8FET16FEF4GEF-DC48	Eight 10/100M electric ports, 16 10/100M optical ports, four 1000M optical ports, one console port, one DC power supply
SM3400-8FET16FEF4GEF8E1-DC48	Eight 10/100M electric ports, 16 10/100M optical ports, four 1000M optical ports, one console port, eight E1/T1 interfaces supporting PWE3, one 2M/25M clock input interface, one DC power supply
SM3400-28GEF-AC	28 1000M optical ports (including 24 downstream ports and four upstream optical ports), one console port, one AC power supply
SM3400-28GEF-DC48	28 1000M optical ports (including 24 downstream ports and four upstream optical ports), one console port, one DC power supply
<b>Performance parameters</b>	
Hardware	128MByte RAM, 32MByte FLASH
Switching capacity	12.8Gbps (excluding SM3400-28GEF) 56Gbps (SM3400-28GEF)
Throughput	Wire speed
Items in MAC table	16K
The number of selective VLANs	4094
The number of Link Aggregation groups	16
The number of L2 multicast groups	1024

The number of L3 multicast groups	512
IPv4 route table	8K
The number of VRFs	32
Standards and protocols	
VPN	EPL, EVPL, E-LAN (comply with MEF9)
OAM	802.1ag, 802.3ah, E-LMI
QoS	Each port supports eight queues; Supports 802.1q and can change the packet priority; Flow shaping: srTCM (single-rate three-color mode), trTCM (dual-rate three-color mode); SLA: CIR, PIR, CBS Priority mapping: the mapping among 802.1p, COS, DSCP Ingress/Egress port rate limiting: 64Kbp granularity, limit the rate based on time segment Supports the flow shaping at the out direction Queue scheduling: SP, RR, WRR, WDRR Block workaround: Tail Drop, sRED
50m protection	Adopts 50ms Ethernet ring protection protocol (EIPS); Supports single ring, dual-ring/multi-ring, crossover ring, tangent ring
TDMoIP	Supports E1 and T1, up to eight 8 E1/T1 interfaces, RJ40 physical interface Supports SAToP, CESoPSN, AAL1, AAL2, and HDLC bearing mechanisms Supports eight independent clocks, including internal clock, external clock, loop clock and RTP clock Supports 64 independent TDMoIP data flow Compatible with ITU-T Y.1413, Y.1414, MEF3, MEF8, IETF PWE3
VLAN	The value range of VLAN ID is 1–4094 Supports dividing VLANs based on port, protocol, MAC, and IP address Port VLAN type: Access, Trunk, Hybrid Supports Super-VLAN and Sub-VLAN Supports GVRP
QinQ	Complies with IEEE 802.1ad Supports modifying label protocol ID Supports up to 1024 QinQs Supports selective QinQ based on C-VLAN ID Supports the mapping between C-VLAN and S-VLAN
Multi-cast	Supports IGMP Snooping Supports IGMP fast adding/leaving Supports MVR Supports PIM, PIM-DM, PIM-SM Supports multicast ACL Supports 1024 multicast data flows
Security	Supports IP Source Address spoofing check Supports LAND attack check

	<p>Supports SYN Flood check</p> <p>Supports Smurf attack check</p> <p>Supports Ping Flood attack check</p> <p>Supports Teardrop attack check</p> <p>Supports Ping of Death attack check</p> <p>Supports Netbios/Samba filtering</p> <p>Supports port isolation</p> <p>Supports port monitoring</p> <p>Supports port security</p>
Authentication	<p>Supports IEEE 802.1x</p> <p>EAP trunk working mode</p> <p>EAP ending working mode</p> <p>Based on MAC address and port</p> <p>Compatible with Windows client</p> <p>Supports Auto VLAN</p> <p>Supports Guest VLAN</p> <p>Supports Radius, nTACAS+</p>
Availability	<p>Supports VRRP, VBRP</p> <p>Supports UDLD</p> <p>Supports dual power redundancy</p>
Configuration and management	<p>Supports SSH, Telnet, SNMPV1/2/3</p> <p>Supports outband Console port, and Ethernet port (shared with service Ethernet port) management</p> <p>Supports Masterplan management and third-party network management system</p> <p>Supports SPAN</p> <p>Supports sFlow</p>
L2 protocol	<p>IEEE 802.3, IEEE 802.3u, IEEE 802.3z, IEEE 802.3x, IEEE 802.1p, IEEE802.1q, IEEE 802.1v, IEEE 802.1ad, IEEE 802.1s/d, RFC2236</p>
L3 protocol	<p>Static route, RIPv1/v2, OSPF, BGP4, IGMP, PIM-SM, PIM-DM, VRRP, IPv4 protocol stack, UDP/TCP</p>
Upper layer application	<p>HTTP, TELNET, FTP/TFTP, DHCP, SNMP V1/V2/V3, SNTP, NTP</p>
Physical indexes	
Demission (W×D× H)	<p>S3400-28GEF: 444x280x43.8mm</p> <p>S3400-24FET4GEFA: 444x220x43.8mm</p> <p>Other models: 444×240x88.1mm</p>
Weight	<p>About 3.5Kg (SM3400-24FET4GEFA)</p> <p>About 4.5Kg (SM3400-28GEF)</p> <p>Other models: about 8Kg</p>
Power supply	
Input voltage (AC)	<p>100-240V: 50Hz/60Hz</p>
Input voltage (DC)	<p>-40~-60V</p>
Power consumption	<p>About 22W (SM3400-24FET4GEFA, SM3400-24FET4GEF, SM3400-24FET4GEF8E1);</p> <p>About 32W (SM3400-8FET16FEF4GEF, SM3400-8FET16FEF4GEF8E1, SM3400-28GEF);</p> <p>About 390W (24-port POE is optional)</p>
Environment parameters	
Working temperature	<p>0-55℃</p>
Working humidity	<p>5-90% no-condensing</p>

# Order Information

Product Model	Description
<b>Host</b>	
SM3400-24FET4GEFA-AC	Mandatory configurations: 24 10/100M electric ports, four 1000M optical ports, two alarm input/output interfaces, one console port, one AC power supply
SM3400-24FET4GEFA-DC48	Mandatory configurations: 24 10/100M electric ports, four 1000M optical ports, two alarm input/output interfaces, one console port, one DC power supply (two power input interfaces are provided)
SM3400-24FET4GEF-AC	Mandatory configurations: 24 10/100M electric ports, four 1000M optical ports, one console port, one 60W AC power supply Optional configurations (only one of the following can be selected): <ol style="list-style-type: none"> <li>One 60W AC power AD60-1S003Q2 as the dual power supply</li> <li>POE module POE15-8PSE; one, two or three POE15-8PSE can be configured (note: each POE15-8PSE needs to be configured with one AD150-1S007A power)</li> </ol>
SM3400-24FET4GEF8E1-AC	Mandatory configurations: 24 10/100M electric ports, four 1000M optical ports, one console port, eight E1/T1 interfaces supporting PWE3, one 2M/25M clock input interface, one 60W AC power supply Optional configurations (only one of the following can be selected): <ol style="list-style-type: none"> <li>One 60W AC power AD60-1S003Q2 as the dual power supply;</li> <li>POE module POE15-8PSE; one, two or three POE15-8PSE can be configured (note: each POE15-8PSE needs to be configured with one AD150-1S007A power);</li> </ol>
SM3400-24FET4GEF-DC48	Mandatory configurations: 24 10/100M electric ports, four 1000M optical ports, one console port, one 500W DC power supply Optional configurations (only one of the following can be selected): <ol style="list-style-type: none"> <li>One DC power DD500-5D002Q1 as the dual power supply;</li> <li>POE module POE15-8PSE; one, two or three POE15-8PSE can be configured;</li> </ol>
SM3400-24FET4GEF8E1-DC48	Mandatory configurations: 24 10/100M electric ports, four 1000M optical ports, one console port, eight E1/T1 interfaces supporting PWE3, one 2M/25M clock input interface, one 500W DC power supply Optional configurations: <ol style="list-style-type: none"> <li>One DC power DD500-5D002Q1 as the dual power supply;</li> <li>POE module POE15-8PSE; one, two or three POE15-8PSE can be configured;</li> </ol>
SM3400-8FET16FEF4GEF-AC	Mandatory configurations: Eight 10/100M electric ports, 16 10/100M optical ports, four

	<p>1000M optical ports, one console port, one 60W AC power supply</p> <p>Optional configurations (only one of the following can be selected):</p> <ol style="list-style-type: none"> <li>One 60W AC power AD60-1S003Q2 as the dual power supply;</li> <li>POE module POE15-8PSE; one POE15-8PSE can be configured (note: each POE15-8PSE needs to be configured with one AD150-1S007A power);</li> </ol>
SM3400-8FET16FEF4GEF8E1-AC	<p>Mandatory configurations: Eight 10/100M electric ports, 16 10/100M optical ports, eight E1/T1 interfaces supporting PWE3, four 1000M optical ports, one console port, one 2M/25M clock input interface, one 60W AC power supply</p> <p>Optional configurations (only one of the following can be selected):</p> <ol style="list-style-type: none"> <li>One 60W AC power AD60-1S003Q2 as the dual power supply;</li> <li>POE module POE15-8PSE; one POE15-8PSE can be configured (note: each POE15-8PSE needs to be configured with one AD150-1S007A power);</li> </ol>
SM3400-8FET16FEF4GEF-DC48	<p>Mandatory configurations: Eight 10/100M electric ports, 16 10/100M optical ports, four 1000M optical ports, one console port, one 500W DC power supply</p> <p>Optional configurations:</p> <ol style="list-style-type: none"> <li>One DC power DD500-5D002Q1 as the dual power supply;</li> <li>POE module POE15-8PSE; one POE15-8PSE can be configured;</li> </ol>
SM3400-8FET16FEF4GEF8E1-DC48	<p>Mandatory configurations: Eight 10/100M electric ports, 16 10/100M optical ports, four 1000M optical ports, one console port, eight E1/T1 interfaces supporting PWE3, one 2M/25M clock input interface, one 500W DC power supply</p> <p>Optional configurations:</p> <ol style="list-style-type: none"> <li>One DC power DD500-5D002Q1 as the dual power supply;</li> <li>POE module POE15-8PSE; one POE15-8PSE can be configured;</li> </ol>
SM3400-28GEF-AC	<p>Mandatory configurations: 28 1000M optical ports (including 24 downstream ports and four upstream optical ports), one console port, one 60W AC power supply</p> <p>Optional configuration: One 60W AC power AD60-1S003Q2 as the dual power supply</p>
SM3400-28GEF-DC48	<p>Mandatory configurations: 28 1000M optical ports (including 24 downstream optical ports and four upstream optical ports), one console port, one 500W DC power supply</p> <p>Optional configuration: One DD500-5D002Q2 power as the dual power supply</p>
<b>Modules</b>	
POE15-8PSE	Ethernet power supply module. It can provide power for eight Ethernet interfaces. Each Ethernet port can provide up to 15W power. As PSE, it is inserted in S3400 main board.
DD500-5D002Q1	500W DC power supply, used for: SM3400-24FET4GEF-DC48 SM3400-24FET4GEF8E1-DC48 SM3400-8FET16FEF4GEF-DC48 SM3400-8FET16FEF4GEF8E1-DC48
DD500-5D002Q2	500W DC power supply, used for: SM3400-28GEF-DC48

AD60-1S003Q2	60W AC power supply, used for: SM3400-24FET4GEF-AC SM3400-24FET4GEF8E1-AC SM3400-8FET16FEF4GEF-AC SM3400-8FET16FEF4GEF8E1-AC SM3400-28GEF-AC
AD150-1S007A	150W AC power supply module, providing power for POE15-8PSE

# Typical Applications

## MAN Access and Aggregation

MyPower S3400 is used for the MAN Ethernet access at the aggregation layer. It adopts the Ethernet ring protection protocol (ERPP) and provides 50ms network protection capability to ensure the reliable operation of the Triple-play service (VoIP, IPTV and Internet) of carriers. The perfect multicast support and advanced QoS support ensures the normal running of the services.

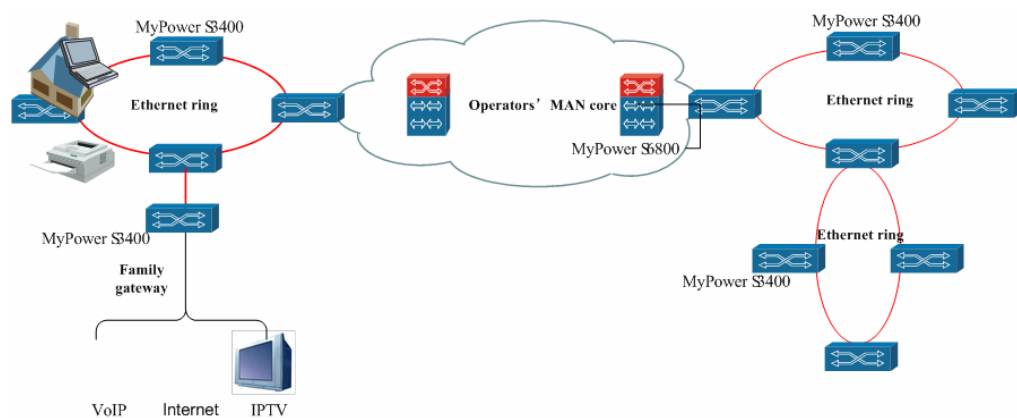

## IP Unified Bearing Multiple Services of Base Station

With the development of communication technology and enterprises' informationization construction, the carriers need to access the 2G (GSM), 2.5 (GPRS), 3G (WCDMA and TD-CDMA) mobile services of the base station. Besides, the carriers hope to promote the WIFI and WiMAX wireless services based on the base station and the VPN service of commercial customers. MyPower S3400 integrates the features of PoE, TDMoIP, and Ethernet SFP interface. The selective QinQ technology and advanced QoS technology meet the stable and reliable running of the services.

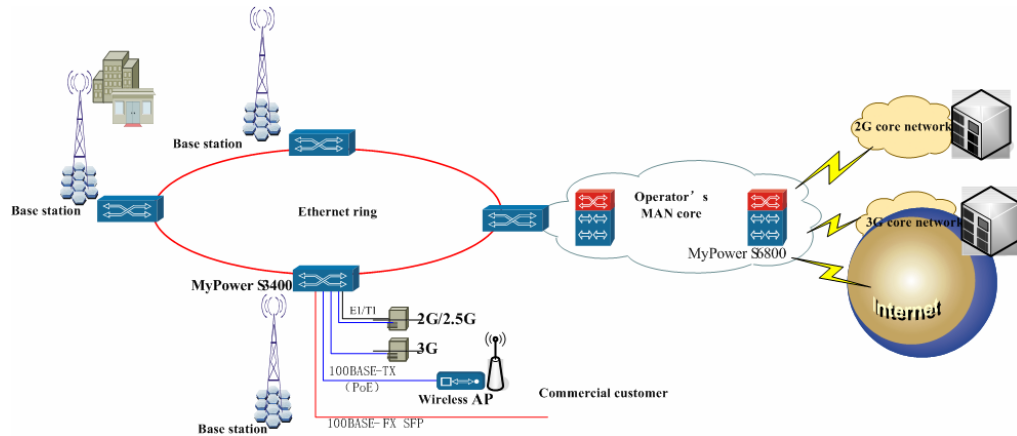

## Business Building Access

Enterprise customers are important for carriers and the main income source. Therefore, ensuring enterprise customer access and the reliable, stable and high-efficiency running of the VPN service and Internet access service of enterprise customers are important for operators. The QinQ and Multi-VRF technologies of S3400 can provides L2 and L3 VPN access for enterprise customers to inter-connect the private networks of enterprise offices. The advanced QoS technology of S3400 ensures the SLA of customers; the dual power supplies and 50ms service switchover ensures the network continuity; the TDMoIP function helps the operators to access enterprises' TDM service through unified IP network.

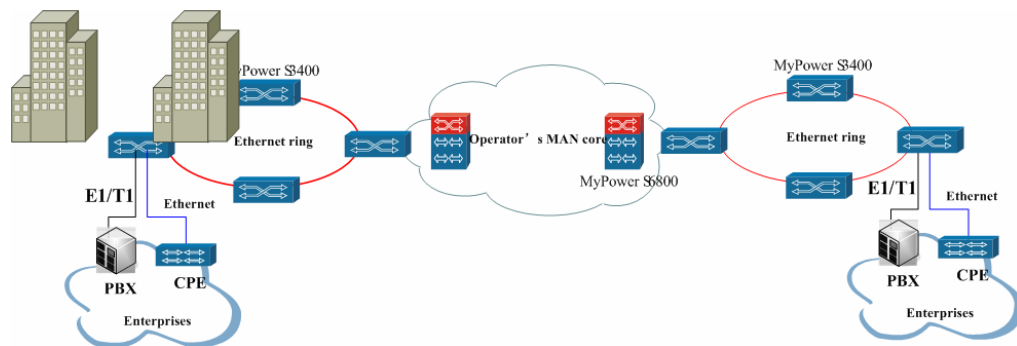

## L2 VPN Service

L2 VPN service helps customers to inter-connect the remote institutions through operators' network and the private connection is not needed. MyPower S3400 is fit for deploying Ethernet MAN access. It provides 802.1Q tunnel and L2PT. It helps operators to provide L2 VPN services for the enterprises or commercial customers. It supports the three VPN services defined by MEF, including Ethernet Private Line (EPL), Ethernet Virtual Private Line (EVPL), and Ethernet LAN (E-LAN).

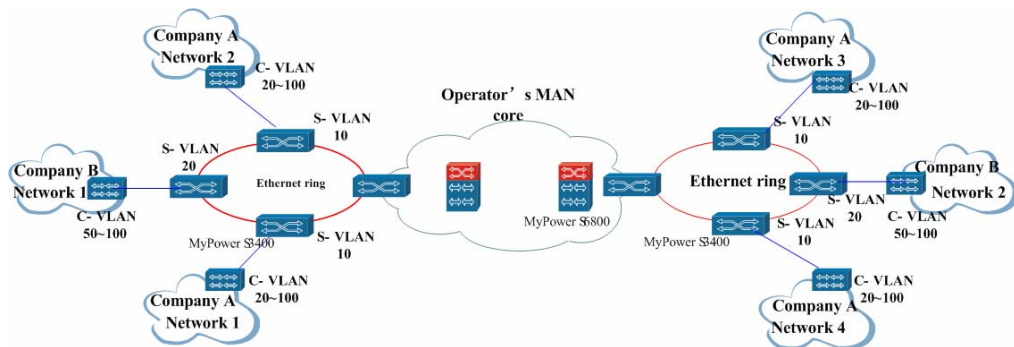

## L3 VPN Service

The commercial customers often have branches in the country and even the world. The branches cannot be connected through L2 VPN. Therefore, L3 VPN technology is adopted. The L3 VPN service provides a single control platform, advanced QoS and security for different transmission technologies. With Multi-VRF CE, S3400 series provides independent route table function for each customer to ensure the separation of customers' route information.

