



# Intel® Dialogic® D/82JCT-U

## Advanced PBX Integration Board

The Intel® Dialogic® D/82JCT-U board offers advanced digital connectivity to many popular private branch exchanges (PBXs) for unified and Internet-ready call, voice, and fax processing applications in small- to medium-sized



enterprises. Featuring programmable soft-ports capable of supporting voice, fax, call handling, and host-based speech technologies, the D/82JCT-U board reduces the cost of ownership for systems requiring multimedia functionality. The universal PBX interface of the D/82JCT-U board offers downloadable firmware for a selection of widely used telephone equipment switches. Support for advanced PBX features such as called and calling number identification, message waiting notification, busy lamp fields, and disconnect supervision is useful for developing unified messaging, interactive voice response (IVR), and call management solutions. By choosing the D/82JCT-U board for enterprise applications, developers eliminate the complexities associated with analog or T-1 integration as well as costly investments in proprietary computer-telephone integration (CTI) links.

Intel in  
Communications

### Features and Benefits

Eight digital interfaces connecting to Avaya® DEFINITY®, Nortel® Meridian® and NorStar®, Mitel®, and Siemens® Hicom® and CBX 9000® Series

— Tight, direct switch integration to many popular PBXs

Digital interfaces to the PBX

— Eliminates the need for expensive digital/analog conversion cards or serial ports

Access to switch information

— ANI, DNIS, date/time, reason for call redirection, etc.

Advanced digital connectivity

— Provides more information from the PBX than analog without the need for separate links and third-party call control

Phone-emulated supervised/unsupervised transfers

— Faster, more reliable transfers than analog

Disconnect supervision

— Faster than analog

Supports GSM and G.726, the coders of choice for Internet-ready unified messaging applications

— Enables messaging integration with many popular email servers and applications

Two channels of Softfax per card, sharable across CT Bus

— Enables scalable fax capability at a low cost by eliminating the need for additional fax hardware

H.100 connectivity allows systems to scale from 8 through 64 ports

— Meets the density requirements of the most widely deployed enterprise computer telephony (CT) solutions

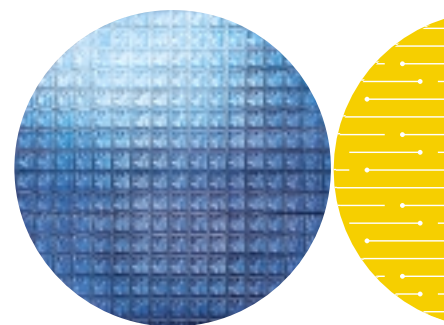

## Features Programmable Resources for Multimedia Functionality

In addition to support for eight ports of voice-processing features, the D/82JCT-U board lets developers select from standard coders such as GSM and G.726 for transmitting voice messages through the private or public Internet. Along with voice media, the D/82JCT-U board features Softfax: two ports of mappable 14,400 b/s (V.17) transmit and 9600 b/s (V.29) receive fax instances. The D/82JCT-U is also optimized for host-based speech applications, which let developers offer host-based automatic speech recognition (ASR) and text-to-speech (TTS) as part of their solutions without adding expensive hardware.

Developers will be able to choose from any of the following switches and phone types:

PBX Switch Manufacturers	Phone Emulations Supported	Available Switches
Avaya	7434 (4-wire)	DEFINITY, System 75/85
Avaya	8434 (2-wire)	DEFINITY (G3 V4 and higher)
Mitel	Superset 420	SX-50 only
Mitel	Superset 430	SX-200ML, SX-2000
Nortel Networks	M7324	Norstar
Nortel Networks	M2616	Meridian 1
Siemens	Optiset E	Hicom
Siemens	ROLMphone 400 (RP 400)	CBX 9000 Series

Compared to other integration methods, digital integration offers more features and greater reliability. Call transfers are quicker and developers do not run the risk of dropped transfers as they do with analog “hook flash” methods. The switch offers the application a wealth of information including called and calling number identification, the reason a call was redirected, and date and time stamps. These features are valuable for customer premises applications. In addition, the D/82JCT-U board offers a single programming interface, eliminating the need for complex, switch-specific programming interface management as well as voice, fax, and speech programming interfaces.

## Hardware and Software Environments

The D/82JCT-U board is offered in a PCI long-card form factor for easy implementation. Systems can scale readily from 8 ports to 64 ports using the industry-standard CT Bus. The D/82JCT-U board is supported under Windows\* NT\*, Windows 2000\*, and Linux\*.

## Applications

- Voice mail/voice messaging
- Internet-based unified messaging (UM)
- Interactive voice response/interactive media response (IVR/IMR)
- Automatic call distribution (ACD)
- Telecom/data convergence solutions

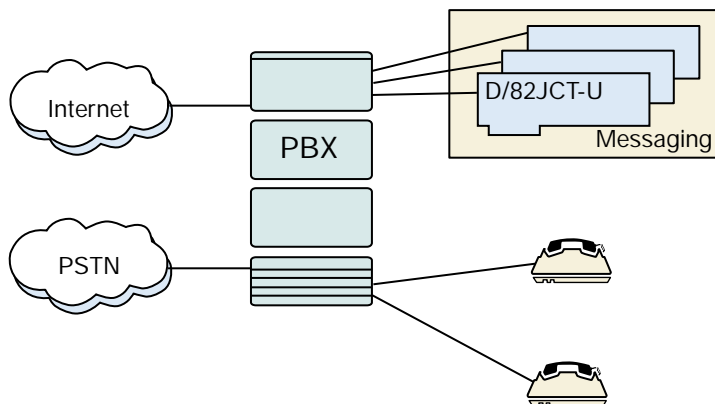

Figure 1. D/82JCT-U Configuration Diagram

## Configurations

The D/82JCT-U board provides PBX integration with an industry-standard CT Bus interface enabling access to CT Bus supported complementary technologies. A dual-processor architecture consisting of a digital signal processor (DSP) and a general purpose microprocessor handles all telephony signaling and performs DTMF (touch tone) and audio/voice signal processing tasks. When used with the supported PBXs, the D/82JCT-U board provides a flexible platform for developing integrated computer telephony (CT) applications. Developers can port current applications from the D/42 series of PBX integration boards to D/82JCT-U boards with minimal software modifications, and create more efficient applications that are portable for use with multiple PBXs.

Use the D/82JCT-U board to build sophisticated, multimedia communications systems that incorporate capabilities such as voice processing, fax, TTS, and ASR. The D/82JCT-U board shares a common hardware and firmware architecture with other SCbus and CT Bus based boards for maximum flexibility and scalability. You can add features and grow the system while protecting your investment in hardware and application code. Applications can be ported to different PBX integration solutions with only minimal modifications.

The D/82JCT-U board installs in computers with a Intel® Pentium® processor and compatible computers. Each board occupies a single expansion slot and up to eight boards can be configured in a single system. The number of boards and channels supported varies depending on the application, the operating system, the amount of disk I/O required, the number of CT Bus

loads per board, and the host computer's CPU(s) and power supply.

The D/82JCT-U board can operate within a mixed chassis containing PCI and ISA board-level products. The board's design incorporates an H.100 connector to simplify the connection to next-generation CT Bus products.

The D/82JCT-U board can access called number identification for calls transferred from within the PBX, access trunk identification for calls originating outside the PBX, and control message waiting indicators for message notification.

Downloaded firmware algorithms executed by the on-board DSP provide variable voice coding at 24 and 32 Kb/s Adaptive Differential Pulse Code Modulation (ADPCM), and 48 and 64 Kb/s  $\mu$ -law or A-law Pulse Code Modulation (PCM). Sampling rates and coding methods are selectable on a channel-by-channel basis. Applications may dynamically switch sampling rate and coding method to optimize data storage or voice quality as the need arises. These firmware algorithms also provide reliable DTMF detection, DTMF cut-through, and talk off/play off suppression over a wide variety of telephone line conditions.

Intel voice products offer a rich set of advanced features including innovative DSP technology and signal processing algorithms for building the core of any CT system. With industry-standard PCI bus expansion boards and a variety of channel densities to choose from, you can integrate Intel voice products easily into your PBX system at a cost-effective price and performance level.

## Software Support

The Intel® Dialogic® System Releases for the Windows and Linux operating systems provide support for the D/82JCT-U board and contain a set of tools for developing sophisticated, multimedia communications applications.

The D/82JCT-U board also supports Board Watch, SNMP-compatible software for remote CT board management. Board Watch software simplifies the management of CT devices and lowers the total cost of operation. Centralized management capabilities provide a single point of configuration and inventory for all network devices. Fault management for high availability systems includes diagnostics, detection, and recovery capabilities.

The D/82JCT-U also supports the D/82 R4 API, which provides developers with a single set of basic functions that can be used by any supported switch and can be sent directly to the switch without additional hardware support. Functioning as an extension of the standard voice API, the D/82 R4 API allows developers to take advantage of the following advanced PBX features:

- Called/calling number identification — Usually two sets of digits representing either a trunk line or extension. Tells an application where a call originated and to what extension it was directed.
- Retrieve LCD/LED prompts and indicators — Allows an application to determine what kind of prompts or indicators have been set
- Read displays — Allows an application to “read” display information such as hook state, messages, features, and other ASCII text

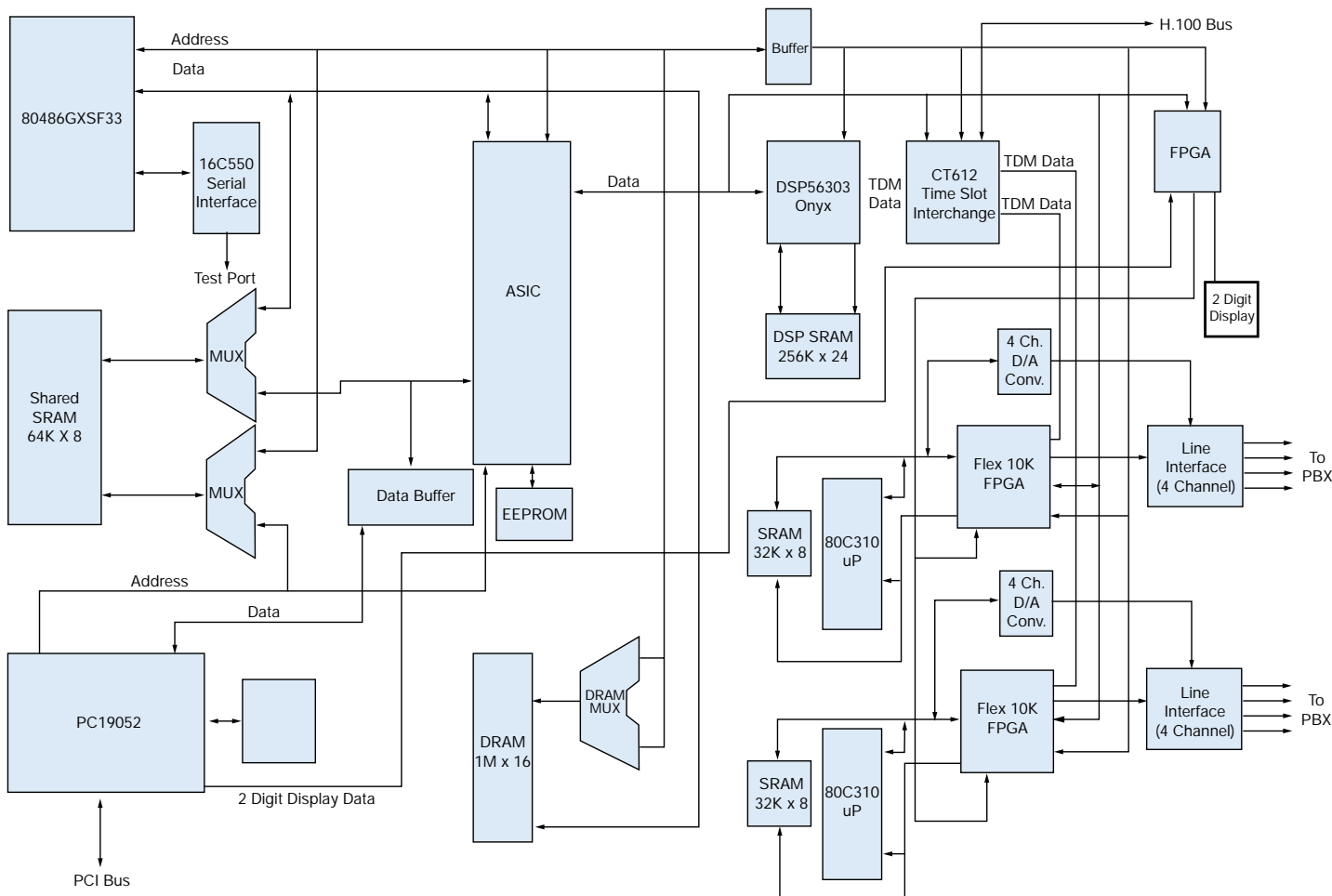

Figure 2. D/82JCT-U Block Diagram

## Functional Description

The D/82JCT-U board is an eight-port voice processing PBX integration board with Group 3 fax support. Each port is a digital interface that connects directly to the station side of various PBXs with the appropriate downloadable software. The D/82JCT-U board is designed around a proven dual-processor architecture and consists of two primary sections: the PBX interface, and the voice and fax processing engine.

In addition to having all the standard features of a voice processing board, the D/82JCT-U board can access enhanced PBX station set features such as:

- Call transfer
- Turn phone message waiting indicators on or off
- Receive called number identification
- Receive positive disconnect supervision
- Access PBX features using dial strings

Each line interface on the D/82JCT-U board receives PCM digital voice and control data from the PBX station interface port (see Figure 2). The digital voice signals are compressed and processed by a DSP.

Control data from the PBX passes through the digital duplexer to a command processor where it is converted from PBX format to D/41D format. This serial bit stream is then converted into a parallel bit stream that is sent via the local bus to the on-board control processor that either acts on the information or passes the event to the application.

Incoming data for each channel is divided into separate voice and control data signaling portions. The voice portion contains the digitized voice data for every channel, while the control data-signaling portion contains the telephone and special feature signaling information for every channel.

The D/82JCT-U has a dual-processor architecture that combines the signal processing capabilities of a DSP

with the decision-making and data movement functionality of an Ultra Low-Power Intel486™ GX processor. This dual-processor approach offloads many low-level decision-making tasks from the host computer and thus enables easier development of more powerful applications. This architecture handles real time events, manages data flow to the host PC for faster system response time, reduces host PC processing demands, processes DTMF and telephony signaling, and frees the DSP to perform signal processing on the incoming call.

The PBX interface is the electrical and functional link between the D/82JCT-U board and PBX station interface. The purpose of this interface is to transmit and receive voice, fax, and signaling information to and from the PBX.

In the receive mode, each of the eight PBX interfaces converts network PBX data to PCM data and applies the incoming bit stream to the CT612 chip. The CT612 ASIC distributes the data onto pre-assigned time slots on the local TDM bus. Voice (and fax) transmissions are routed to the DSP voice-processing engine. In transmit mode, the DSP voice-processing engine and data-processing engine transmit voice and data respectively in different assigned time slots to the SC4000 device. The voice/data is passed on the local TDM bus to the S/T interface, and is then transmitted to the ISDN network.

The CT612 ASIC also serves to exchange voice and fax between a time slot on the local TDM bus and a time slot on the CT Bus. The D/82JCT-U board can transmit or receive voice or fax information to and from an external device over the CT Bus.

The D/82JCT-U board has an onboard microprocessor (Intel486 GX processor) and a high-speed DSP (Motorola\* DSP56303) to provide voice and call processing. When the system is initialized, firmware known as Springware is downloaded from the host PC to the board. The firmware makes the board "intelligent" and enables easy feature enhancements and upgrades.

The firmware offers several features including speed control, volume control, global tone detection, and positive voice detection. The speed control feature allows callers to change the speed of replayed messages without any pitch distortion. The volume control feature allows callers to adjust the volume of

messages before or during playback. Global tone detection allows applications to detect special intercept tones, fax tones, modem tones, non-standard PBX tones, or user-defined tones such as tones in international networks.

The D/82JCT-U board processes voice with a Motorola DSP56303 voice-processing engine. The digital signal processing (DSP) resource receives voice and fax via the CT612 chip. The Motorola DSP56303 processes the digitized voice data using firmware loaded in code/data RAM. Each DSP56303 performs the following signal analysis and operations:

- Enables automatic gain control to compensate for variations in the level of the incoming audio signal
- Applies an ADPCM or PCM algorithm to compress the digitized voice and save disk storage space
- Detects the presence of tones — DTMF, MF, or an application-defined single or dual tone
- Uses silence detection to determine if the line is quiet and the caller is not responding

For outbound voice, the DSP performs the following operations:

- Expands stored, compressed audio data for playback
- Adjusts the volume and rate of speed of playback upon application or user request
- Generates tones — DTMF, MF, or any application-defined general-purpose tone

The dual-processor combination also performs outbound dialing and call progress monitoring

- Transmits an off-hook signal to the telephone network
- Dials out (makes an outbound call)
- Monitors and reports results: line busy or congested; operator intercept; ring, no answer; or if the call is answered, whether answered by a person (PVD), an answering machine (PAMD), a fax machine, or a modem.

When recording speech, the DSP can use different digitizing rates from 24 to 64 Kb/s as selected by the application for the best speech quality and most efficient storage. The digitizing rate is selected on a channel-by-channel basis and can be changed each time a record or play function is initiated. Outbound signal processing is the reverse of inbound processing.

The DSP- processed speech is transmitted via the control microprocessor to the host PC for disk storage. When replaying a stored file, the microprocessor receives the voice information from the host PC via a shared buffer memory and passes it to the DSP. The DSP then sends the digitized voice to the digital duplexer in PBX format for transmission to the PBX.

Signaling data (on-/off-hook, ringing, calling number, and special feature signaling data) is converted from PBX message format by the command processor, passed to the on-board control processor, and transmitted to the application via a dual-port shared RAM and the host PCI bus.

An onboard control processor manages the flow of information between the voice engine and the host PC. The control processor controls all operations of the D/82JCT-U board and interprets and executes commands from the host PC. The processor handles real-time events, manages data flow to the host PC to provide faster system response time, reduces PC host processing demands, processes DTMF and PBX

signaling before passing them to the application, and frees the DSP to perform signal processing.

The control processor and the host PC communicate via the shared RAM that acts as an input/output buffer, increasing the efficiency of disk file transfers. The RAM interfaces with the host PC via the PCI bus. All operations are interrupt-driven to meet the demands of real-time systems. When the system is initialized, firmware is downloaded from the host PC to the onboard code/data RAM and DSP RAM to control all board operations.

The traffic controller ASIC (TCA) is the interface to the Intel486 GX processor that handles all peripheral devices (CT612, DSP, HDLCs, PBX interface) and host PC functions across the PCI bus. The D/82JCT-U board is plug-and-play enabled. The board ID/slot number configuration is handled exclusively by software, using a configuration manager. The assigned board ID/slot number is presented on a hexadecimal display located on the PCB bracket.

## Technical Specifications<sup>5</sup>

Number of ports	8
Total ports/system	64
Max. boards/system	8
Microprocessor	Intel486 GX processor (80486GXSF33) running @ 28.5 MHz with 2MB DRAM
Digital signal processor	Motorola DSP56303 @ 100 MHz, 24-bit
DSP SRAM	256K SRAM

### Host Interface:

Bus compatibility	PCI
Bus speed	33 MHz
Shared memory	64 KB SRAM configured as two 32K x 16
Base addresses	D0000 (default)

### Telephone Interface:

Support	Avaya 7434 (4-wire), Avaya 8434 (2-wire), Siemens Optiset E, Siemens ROLMphone* 400, Mitel Superset* 420, Mitel Superset 430, Nortel M7324, Nortel M2616
Connectors	36-position mini D cable plug

### Power Requirements:

+5 VDC	3.3 A at 5 volts per board
Operating temperature	0°C to +50°C
Storage temperature	-20°C to +70°C
Humidity	8% to 80% non-condensing
FORM FACTOR:	PCI long form factor card. 12.283 in. long and 4.200 in. high

### Safety and EMI Certifications:

United States	FCC part 68 component registration FCC Part 15 Class A
Canada	IC CS03 component registration IC Class A
MTBF	196,000 hours
Warranty	See <a href="http://www.intel.com/network/csp/products/3144web.htm">http://www.intel.com/network/csp/products/3144web.htm</a>

## Firmware (Springware) Technical Specifications<sup>5</sup>

---

### Audio Signal:

Usable receive range	-42 to +2.5 dBm0
Silence detection	-38 dBm0 nominal, software adjustable <sup>55</sup>
Transmit level	-12.5 dBm0 nominal (weighted average) <sup>55</sup>
Frequency response	24 Kb/s: 300 Hz to 2600 Hz ±3 dB 32 Kb/s: 300 Hz to 3400 Hz ±3 dB 48 Kb/s: 300 Hz to 2600 Hz ±3 dB 64 Kb/s: 300 Hz to 3400 Hz ±3 dB

---

### Audio Digitizing:

Method	G.711 A-law and $\mu$ -law PCM; GSM 610; G.726
Sampling rates	6 kHz, 8 kHz for PCM
Data rates	G.711 A-law and $\mu$ -law PCM; 48 Kb/s

---

### Tone Dialing:

DTMF digits	0 to 9, *, #, A, B, C, D
MF digits	0 to 9, KP, ST, ST1, ST2, ST3
Level	Network compatible
Rate	10 digits/s maximum, software adjustable

---

### Pulse Dialing:

10 digits	0 to 9
Pulsing rate	10 pulses/s, nominal
Break ratio	60%

---

### DTMF Tone Detection:

DTMF digits	0 to 9, *, #, A, B, C, D per Bellcore LSSGR Sec 6
Dynamic range	-39 dBm0 to +0 dBm0 per tone <sup>55</sup>
Minimum tone duration	32 ms, software adjustable
Acceptable twist	10 dB
Signal/noise ratio	10 dB (referenced to lowest amplitude tone)
Talk off	Detects 0 digits while monitoring MITEL speech tape #CM7291. Detects less than 10 digits while monitoring Bellcore TR-TSY-000763 standard speech tapes (LSSGR requirements specify detecting no more than 470 total digits).

---

### MF Tone Detection:

MF digits	0 to 9, KP, ST, ST1, ST2, ST3
-----------	-------------------------------

---

### Speed Control:

Pitch controlled	Available for 24 and 32 Kb/s data rates
Adjustment range	50%

---

### Volume Control:

Adjustment range	40 dB, with programmer-definable increments
------------------	---

---

<sup>5</sup> All specifications are subject to change without notice.

<sup>55</sup> Analog levels: 0 dBm0 corresponds to a level of +3dBm at tip-ring analog point.

## System Hardware Requirements

- The D/82JCT-U board occupies a single expansion slot, and up to eight boards can be configured in a system. The maximum number of ports supported is 64, dependent on the application, the amount of disk I/O required, and the host computer's CPU.
- An 8-port system requires a minimum 90 MHz computer with Pentium processor, Intel® Celeron® processor, or equivalent, with an available PCI bus slot.
- A 64-port system requires a minimum 266 MHz computer with Pentium processor, Celeron processor, or equivalent, with an available PCI bus slot.

## System Software Requirements

The computer containing the D/82JCT-U board must run on one of the following

- Windows NT operating system
- Windows 2000 operating system
- Linux operating system

## Optional Components

Item Market Name	Comments
D82JCTU	Board can be used in the US, Canada, Europe (CE) and supports all of the PBXs listed above in this datasheet and supports +5V PCI expansion slots only.
D82JCTUPCIUNIV	Board can be used in the US, Canada, Europe (CE) and supports all of the PBXs listed above in this datasheet. Similar to D82JCTU, this universal PCI form-factor board supports both +5V and +3.3V PCI expansion slots. <i>(Note: To use this board, you must upgrade to System Release 5.1 or higher software.)</i>
D82UCABLE	Required for production environments. Order one cable for each board. <i>(Note: This cable SKU works on D82JCTU, D82JCTUPCIUNIV, or D42JCTU.)</i>
CABLED82U	Optional kit for use in engineering labs only. <i>(Note: This cable works on D82JCTU, D82JCTUPCIUNIV, or D42JCTU.)</i>
CBLCTB68C4DROP	Connects up to four H.100 connector-equipped boards together, such as D82JCTU and D82JCTUPCIUNIV. Required only if H.100 switching will be used by the application to switch voice or fax resources from one board to another in the system.
CBLCTB68C8DROP	Connects up to eight H.100 connector equipped boards together such as D82JCTU and D82JCTUPCIUNIV. Required only if H.100 switching will be used by the application to switch voice or fax resources from one board to another in the system.
CBLPEBSCB4DROP	Connects up to four PEB/SCbus connector-equipped boards together. Required only to connect D82JCTU or D82JCTUPCIUNIV to PEB/SCbus connector-equipped boards and only if PEB/SCbus switching will be used by the application to switch voice or fax resources from one board to another in the system. CTbus to SCbus adapter required – not included.
CBLPEBSCB8DROP	Connects up to eight PEB/SCbus connector-equipped boards together. Required only to connect D82JCTU or D82JCTUPCIUNIV to PEB/SCbus connector-equipped boards and only if PEB/SCbus switching will be used by the application to switch voice or fax resources from one board to another in the system. CTbus to SCbus adapter required – not included.
CTBUSTOSCBUSADP	Connects H.100 connector-equipped boards such as D82JCTU and D82JCTUPCIUNIV to SCbus connector-equipped boards. Required only when connecting the D82JCTU or D82JCTUPCIUNIV to an SCbus connector-equipped card. H.100 or SCbus cables required – not included.

To learn more, visit our site on the World Wide Web at [www.intel.com](http://www.intel.com)

1515 Route Ten  
Parsippany, NJ 07054  
Phone: 1-973-993-3000  
Fax: 1-973-993-3093

Information in this document is provided in connection with Intel® products. No license, express or implied, by estoppel or otherwise, to any intellectual property rights is granted by this document. Except as provided in Intel's Terms and Conditions of Sale for such products, Intel assumes no liability whatsoever, and Intel disclaims any express or implied warranty, relating to sale and/or use of Intel® products including liability or warranties relating to fitness for a particular purpose, merchantability, or infringement of any patent, copyright or other intellectual property right. Intel® products are not intended for use in medical, life saving, or life sustaining applications. Intel may make changes to specifications and product descriptions at any time, without notice.

\* Other names and brands may be claimed as the property of others.

Intel, Pentium, Celeron, Intel486, Intel Dialogic, and the Intel logo are trademarks or registered trademarks of Intel Corporation or its subsidiaries in the United States and other countries.

The Intel logo is a registered trademark of Intel Corporation.

