

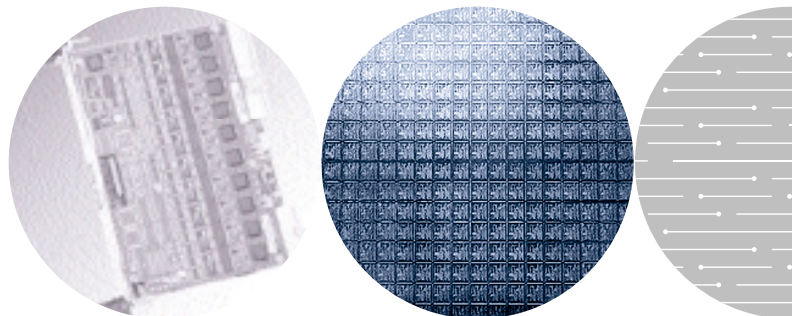

Managed Migration to IP Telephony in a PBX Environment: Intel® NetStructure™ PBX-IP Media Gateway Can Provide the Critical Link

Intel in
Communications



Contents

Introduction	1
Market Research Reveals Trends	2
Connecting IP Phones to the Corporate PBX	3
A Cost-Effective Bridge	3
Basic Features	3
Translates Call Control and Voice Data	4
Understanding How the PBX-IP Media Gateway Works	5
Call Routing	5
Address Translation	6
Gateway Management	7
Monitoring Status and Operation	7
Configuration	7
Deployment	7
Scenario 1: Adding IP at a Corporate Office	8
Scenario 2: Connecting Legacy Phones to an IP-PBX	9
Scenario 3: Connecting to a Remote Office Using IP	10
Scenario 4: Telecommuting	11
Conclusion	12

Executive Summary

Although many enterprises are eager to adopt IP telephony, they see their legacy PBX systems as a roadblock to the cost savings and enhanced applications that IP telephony would bring. This paper will demonstrate that this does not need to be the case. Legacy PBX equipment does not have to be replaced for enterprises to begin a phased migration to IP telephony. The Intel® NetStructure™ PBX-IP media gateway makes the implementation of IP technology in PBX systems possible right now.

The PBX-IP media gateway provides a managed migration to IP because it enables the seamless convergence of voice, data, and fax across IP networks into a single, integrated enterprise network without any expensive changes to the circuit-switched network. It easily joins legacy hardware and the latest technology, simultaneously protecting a company's investment as it accelerates growth.

The PBX-IP media gateway allows users to receive both voice and data content in a single call over a managed packet network (LAN, WAN, or VPN) that interfaces directly to the enterprise PBX. Remote users require less equipment but receive the same content and level of access as users in the corporate office, yet the enterprise does not need to invest in new network or PBX equipment. Enterprises can take a phased approach to a fully converged voice and data network while prolonging the useful life of legacy switching equipment.

Introduction

The benefits of a converged network are compelling. In an article entitled "The shape of phones to come" (March 2001), *The Economist* reported that "the corporate sector is beginning to take network convergence seriously." One reason for this heightened interest is that the technology used to packetize voice communications and transmit them over a data network, which is known as IP telephony, is readily available and provides substantial benefits. By comparing IP telephony with traditional circuit-switched telephony, the increased interest in IP telephony in the enterprise is easy to understand:

- **Dramatically reduced bandwidth usage.** IP telephony can use far less bandwidth than circuit-switched telephony, generally by a factor of eight or more. A standard voice circuit uses 64 kilobits per second (Kbps), but IP telephony can be configured to use 6 to 8 Kbps, and sometimes as little as 2.4 Kbps.
- **Valuable control information transmitted simultaneously.** Many traditional voice circuits allow for no additional data other than the voice transmission. Packet-switched networks send voice communications in packets whose headers can contain additional information about the transmission.
- **Many new services possible.** Because IP telephony technology treats voice and data uniformly and Custom Local Area Signaling Services (CLASS) are easy to implement, many new services are possible, such as Web-enabled contact centers and unified messaging.
- **Reliable, scalable, easy to use.** Deployment is easy, because IP telephony does not use a new infrastructure, but rather the data communications network that is already in place. Implementation is achieved through dedicated gateways that can be based on open standards platforms for reliability and scalability.

Although many enterprises are eager to adopt IP telephony, they see their legacy PBX systems as a roadblock to the cost savings and enhanced applications that IP telephony would bring. This paper will demonstrate that this does not need to be the case. Legacy PBX equipment does not have to be replaced for enterprises to begin a phased migration to IP telephony. The PBX-IP media gateway makes the implementation of IP technology in PBX systems possible right now.

The PBX-IP media gateway allows enterprises to:

- Interface to an existing PBX without replacing most current equipment
- Use new value-added productivity applications on their data network
- Simplify system integration
- Provide “digital phone” capabilities anywhere on the IP network

With the PBX-IP media gateway, enterprises, Value-Added Resellers (VARs), and developers alike can benefit from IP telephony, and move gradually towards what *The Economist* calls “the network that connects everything to everything.”

Market Research Reveals Trends

The investment in the installed base of traditional circuit-based PBXs is very large. In its *Infotrack for Enterprise Communications, Second Quarter 2000* report, the Phillips Group estimated that the combined installed base of Lucent, Nortel, and Mitel PBXs was about 30 million lines at the end of 2000. However, despite a sluggish economy, Voice over Internet Protocol (VoIP) gateway and switching applications are growing.

Synergy predicts that “enterprise IP Telephony sales are on a growth path to displace over 20 percent of traditional PBX sales over the next three to four years.” Consequently, Synergy also forecasts a 34.6 percent compounded annual growth in VoIP gateway and switching applications from 2002 to 2006. Products will be needed to bridge the gap between traditional circuit-switched and IP networks for several years. See Figure 1.

VoIP gateways and switching applications are popular because they allow enterprises to control their transition to a converged network without scrapping their legacy telecom equipment. The PBX-IP media gateway is an excellent example of a gateway that enables the transition to IP.

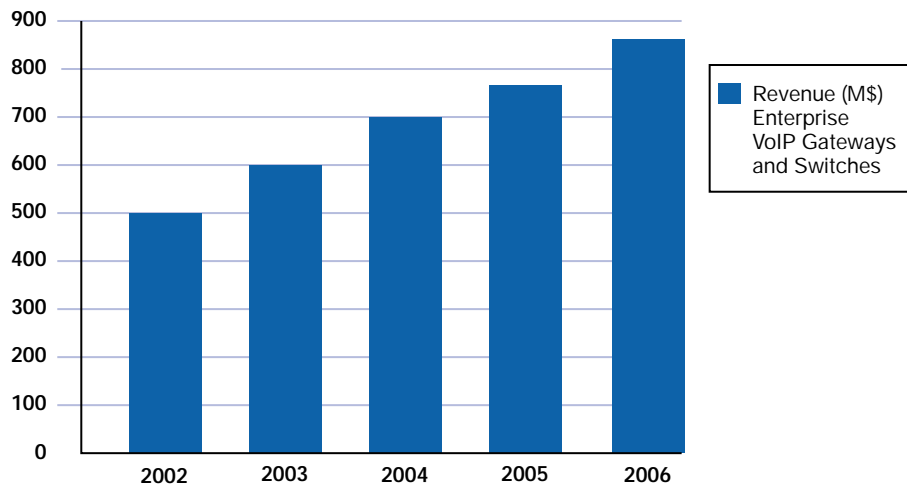

*Source — Synergy Research Q1'02 Forecast (May 24, 2002)

Figure 1. Growth Forecast for VoIP Gateways and Switching Equipment

Connecting IP Phones to the Corporate PBX

How does the PBX-IP media gateway work? What can it do? How is it deployed? All of these questions will be answered in the following sections.

A Cost-Effective Bridge

The PBX-IP media gateway is an open, standards-based, purpose-built device (appliance) that provides a cost-effective bridge between legacy telecom equipment and a managed packet network by converting signals from existing digital telecom equipment to industry-standard IP protocols:

- **Session Initiation Protocol (SIP)** from the Internet Engineering Task Force (IETF)
- **H.323** from the International Telecommunication Union (ITU)
- **T.38** fax from the ITU

These standards, as used by the PBX-IP media gateway, allow IP endpoints to mimic the behavior of traditional telephones. No expensive upgrades to PBX software or hardware are required.

Three types of gateway units are available:

- **Emulating** — Digital network interfaces connect to legacy PBXs from Mitel, Nortel, Avaya, NEC, or Siemens. IP-enables an existing PBX cost-effectively, allowing communication between a circuit-switched telephony network and H.323- or SIP-compatible devices such as IP phones and wireless phones and applications such as softphones and IP-enabled unified messaging.
- **Phone driving** — Digital station interfaces connect to legacy digital telephones from Nortel, Avaya, NEC, or Siemens. Allows IP-PBXs and applications to control legacy digital handsets, thus protecting an investment in these phones while migrating some or all of the core switching architecture to IP.
- **Analog loop start** — Allows IP connection to PBXs that do not have an appropriate digital interface.

The converted protocols can be transmitted over a company's local area network (LAN) or wide area network (WAN) to communications

devices such as IP phones, wireless phones, and IP servers in almost any location, including remote sites or branch offices.

The conversion enabled by the gateway provides a mixed circuit-based and IP-based environment, allowing an enterprise to deploy IP applications and use IP telephony devices without scrapping its legacy telecom equipment.

Basic Features

Because telephony features are important to guarantee a satisfactory user experience, the PBX-IP media gateway supports a variety of primary and supplementary services:

- Silence detection
- Line echo cancellation
- Comfort noise generation
- Call progress tone
- Simultaneous ring at regular desk extension and remote phone
- Use of PBX dial plan to call coworkers with three- or four-digit extensions
- Caller Identification
- Call hold
- Call transfer
- Message waiting indicator control

To simplify deployment, the PBX-IP media gateway also includes the following features:

- **Web browser with context-sensitive Help, DHCP for IP address configuration, SNMP to report alarms, and RS-232 connection for local access** – Allows for easy installation, configuration, and management of the gateway
- **Hot Swap** — Add or remove gateways without affecting the operation of other units

It is also important that a gateway be truly standards-based to protect the investment in all new equipment. For this reason, the PBX-IP media gateway supports:

- **VoIP** — ITU H.323 v3, H.450 supplementary services (including H.450.2/4/7 – call transfer/call hold/message waiting indicator) and SIP per Draft-IETF-SIP-RFC2543bis-05.

Uses Real-Time Transport Protocol/Real-Time Control Protocol (RTP/RTCP) for delivery of voice over the LAN or WAN

- **T.38 Fax over IP** – Emulating units transcode fax from T.30 fax protocol, supporting V.21, V.27, V.29, and V.17 modulation schemes, to T.38 for transmission over a packet network
- **Enhanced signal processing**— A variety of compression algorithms for high voice quality, including G.711 A-law and μ -law (64 Kbps PCM [standard]), G.723.1, and G.729AB
- **Ethernet connection** – 10/100Base-T supporting half-duplex and full-duplex

Translates Call Control and Voice Data

The PBX-IP media gateway communicates to either a legacy PBX or legacy digital telephone via the manufacturers’ own proprietary station link and translates the call control and voice data from the legacy PBX equipment to a managed packet network. This gives H.323 or SIP terminal devices or applications access to the legacy PBX equipment.

The PBX-IP media gateway has eight ports and is positioned between the PBX equipment and the enterprise LAN or WAN via its 10/100 BaseT-Ethernet connection.

Emulating PBX-IP media gateway units are compatible with the PBXs in Table 1.

PBX Manufacturer	PBX Model
Mitel Networks	SX-200, SX-2000
Nortel Networks	Meridian* 1, Norstar*
Avaya Communication	DEFINITY* G3, Merlin Magix* and Legend*
NEC	2400 IMX, 2400 IMG, NEAX* 2000
Siemens	Hicom* 300 series (North American software only)
Analog unit	Various models that support analog loop start station interfaces

Table 1. PBXs Supported

Phone-driving PBX-IP media gateway units support the digital handsets in Table 2.

PBX Digital Phone Manufacturer	Supported Digital Phone Models
Nortel Networks	M2000 series, M7000 series
Avaya Communication	6400, 8400, 4400, and MLX series
NEC	Dterm* III, Dterm E series
Siemens	Optiset* E series

Table 2. Digital Handsets Supported

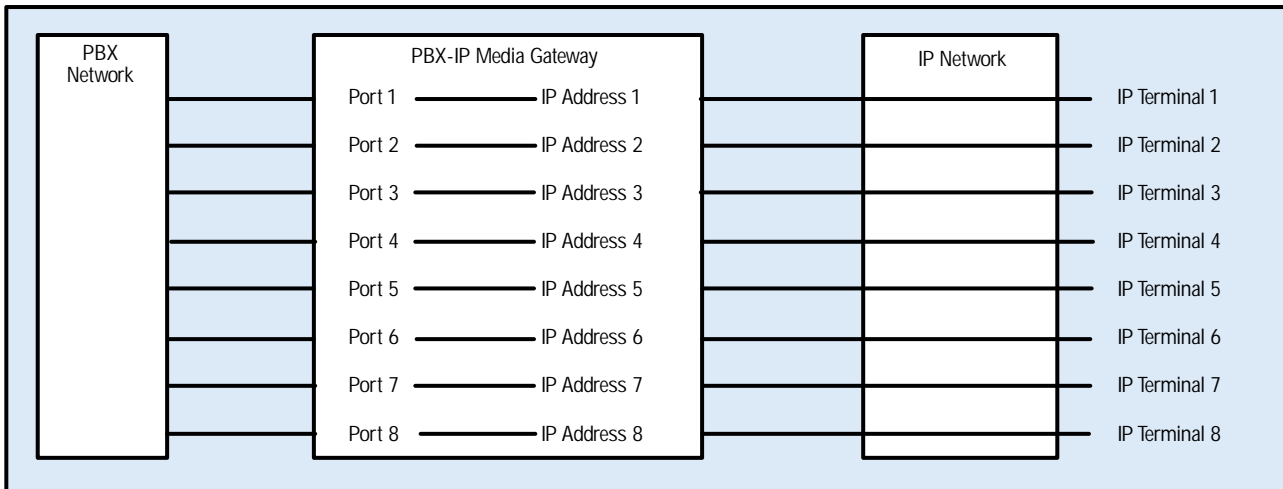

Figure 2. Point-To-Point Routing

Understanding How the PBX-IP Media Gateway Works

To see how the PBX-IP media gateway works, several technical issues must be understood. These include routing and address translation.

Call Routing

The PBX-IP media gateway must route a call from the PBX network to a destination IP address on the IP network. Conversely, calls from the IP network must be routed on a PBX port to a destination telephone number on the PBX network. The PBX-IP media gateway supports two modes of call routing: point-to-point and pooled.

Point-To-Point

In point-to-point routing, a PBX-IP media gateway PBX port is directly assigned to a single specific IP terminal address. Most scenarios that require both inbound and outbound calling will be configured in point-to-point mode.

- **PBX-to-IP** calls are routed from the PBX to the IP terminal that is assigned to the PBX-IP media gateway PBX port on which the call arrived.
- **IP-to-PBX** calls are routed onto the PBX-IP media gateway PBX port that has been assigned to the originating IP terminal's address.

In point-to-point routing, a PBX-IP media gateway PBX port is essentially 'owned' by its assigned IP terminal address. Therefore, only

the IP terminals whose IP addresses are assigned on the IP gateway may originate and receive calls through the IP gateway. See Figure 2 for an illustration.

Pooled

In pooled routing, the PBX-IP media gateway PBX ports serve as a pool of telephony ports. Most systems that require only outbound calling can use the pooled mode. Inbound calling is also supported, but the caller needs to "dial" the destination through two-stage dialing as described below.

- **IP-to-PBX calls** are routed onto the first available PBX-IP media gateway PBX port in a round-robin fashion. IP call information specifies the PBX destination telephone number to be dialed.
- **PBX-to-IP** calls go through two-stage dialing in order to enter the destination IP alias extension (E.164 number).

Using pooled routing, any IP terminal may originate and receive calls through the PBX-IP media gateway. See Figure 3 for an illustration.

Address Translation

Address translation is the conversion of alias names, email addresses, telephone numbers, and dot-com addresses into IP addresses.

In an H.323 environment, the address translator is called a "gatekeeper" while in a

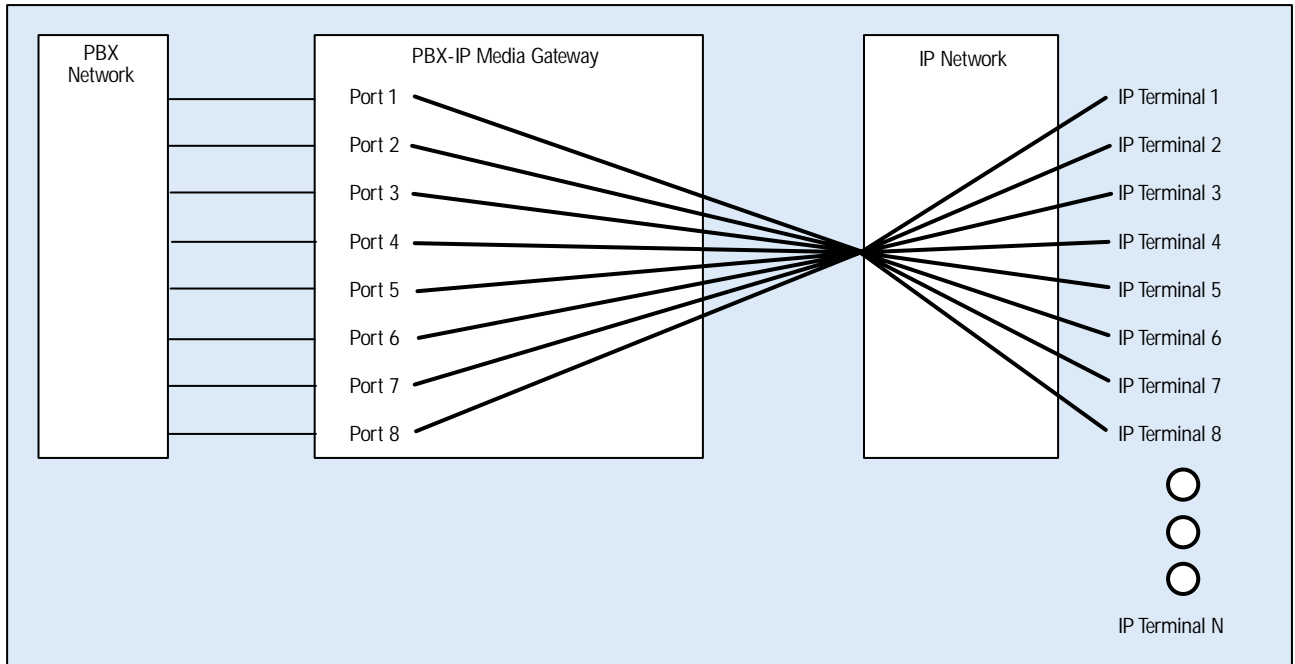

Figure 3. Pooled Routing

SIP environment, the address translator is called a “proxy server.” Because both an H.323 gatekeeper and a SIP proxy server perform the same address translation function as far as the PBX-IP media gateway is concerned, the term “address translator” is used in this paper to avoid confusion.

In general, an address translator is needed to create a good user experience because it enables features such as dial plans and alias translation.

Address Translation Modes

The emulating PBX-IP media gateway supports two modes of address translation: localized and centralized.

Localized translation is the simpler mode of address translation because the PBX-IP media gateway configures destination IP addresses locally and does not require an address translator on the IP network. Each PBX-IP media gateway PBX port is directly assigned a corresponding IP address and calls from the PBX network on a given port are routed to the port’s assigned IP address on the IP network.

Calls from the IP network go to the PBX-IP media gateway PBX port that corresponds to the IP address of the calling party. IP call information specifies the dialed PBX destination telephone number. When in localized translation mode, only IP terminals whose IP addresses are assigned on the PBX-IP media gateway may originate and receive calls through the IP gateway.

With **centralized translation**, the PBX-IP media gateway requires an IP network address translator to perform and control all address translation activities. When centralized translation is used, any IP terminal that has registered an alias extension with the address translator (E.164 number) can receive calls from the PBX-IP media gateway. Similarly any IP terminal on the network may originate calls through the PBX-IP media gateway.

The **phone-driving** PBX-IP media gateway always requires an address translator to map the digital telephones connected to the gateway into IP addresses reachable by other IP devices on the network.

Gateway Management

The PBX-IP media gateway is easy to install, configure, and monitor. The following section provides a brief overview of how some of these management functions work.

Monitoring Status and Operation

The PBX-IP media gateway supports a number of interfaces and standards for monitoring the unit's status and operation.

- **Front-panel LEDs** – Provide simple unit status, Ethernet connection status, and PBX port connection states.
- **Web interface** – Provides a view of unit status, configuration manipulation, and the ability to upgrade the unit firmware.
- **SNMPv1 interface** – Provides a view of unit status and configuration (read only).
- **Serial-port/telnet interface** – Provides interfaces for configuration manipulation and unit diagnostic tracing.

Configuration

Since the PBX-IP media gateway has a Web browser interface, each PBX-IP media gateway is initially configured with a default IP address. This allows the unit to be configured using a Web browser by pointing the Web browser to the default IP address. The unit's IP address must be changed from the default IP address in order to have multiple gateway units in a system.

The gateway also supports the dynamic host configuration protocol (DHCP) so that the gateway's IP address can be configured automatically. At power up, the gateway sends a broadcast message with a vendor ID code identifying itself as a PBX-IP media gateway. If a DHCP server is connected to the network and is configured to recognize a PBX-

IP media gateway, the DHCP server will assign the gateway an IP address. If no DHCP server responds, the gateway uses its default IP address.

The gateway is initially configured with no selected PBX interface. The PBX interface must be chosen through the Web configuration.

Deployment

The PBX-IP media gateway can be used to connect IP telephones to a legacy PBX, integrate network-hosted applications with the PBX, extend the PBX to branch offices, and integrate various voice, fax, and call processing capabilities in an enterprise LAN or WAN environment.

The PBX-IP media gateway can function in several scenarios. Three key scenarios are outlined in this paper.

Scenario 1 – Emulates digital station sets to a digital PBX. This mode uses H.323 or SIP standards to interface with H.323 or SIP devices, such as IP phones or softphones, on the IP-based network at a main site or a home office.

Scenario 2 – Connects remote offices to a main-office PBX over a managed packet network. Basically, the gateway extends PBX functionality to digital phones at a remote site.

Scenario 3 – Drives proprietary digital station sets from an IP device, such as an IP-PBX or IP-server.

Details about deploying the PBX-IP media gateway in various scenarios are given below. An address translator may be required to handle call routing as described earlier in this paper, but for simplicity the address translator is not shown in the figures accompanying the scenarios below.

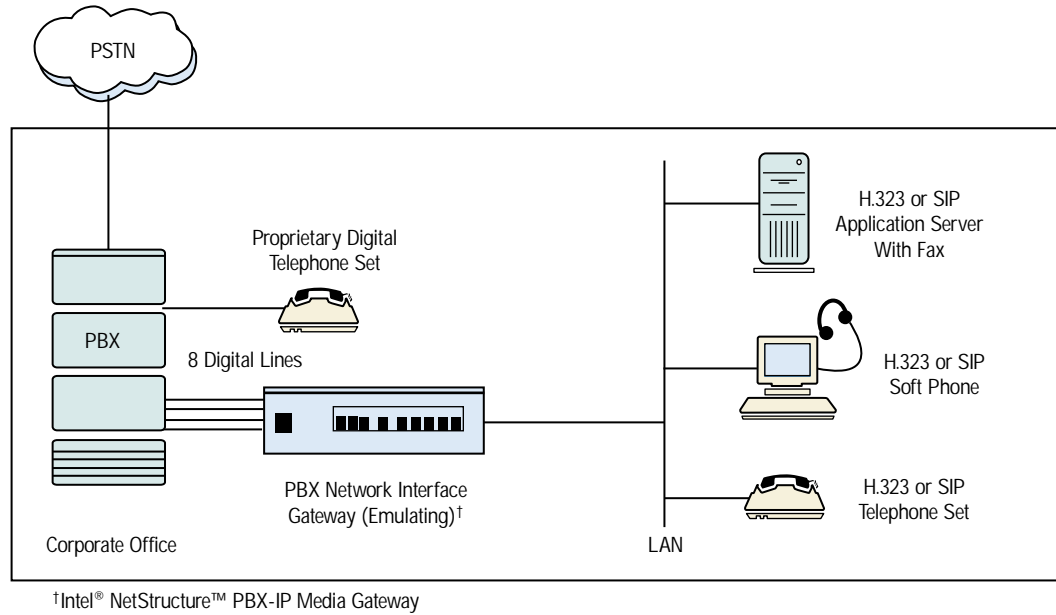

Figure 4. Connecting IP to the Corporate PBX

Scenario 1: Adding IP at a Corporate Office

The PBX-IP media gateway can be used to connect H.323 or SIP phones, softphones, or H.323 or SIP applications servers to the corporate PBX as shown in Figure 4.

Using the PBX-IP media gateway to supply a link between a legacy PBX and new IP technology can supply the following benefits:

- Provides a low cost way to add IP technology to an existing legacy system
- Protects investment in legacy equipment because the equipment does not have to be replaced
- Prevents disruption of service. Because calls can be transferred freely between IP phones and legacy phones, the addition of IP technology to a legacy environment is largely seamless

- Reduces development costs. An application such as voice mail can be written for an IP environment, but used without software changes in a mixed environment enabled by the PBX-IP media gateway

As can be seen in the diagram above, the type of system enabled with the PBX-IP media gateway is very different from a toll bypass gateway setup. To create a toll bypass configuration, gateways are placed at two different sites, and the corporate WAN carries calls between the two sites to avoid the PSTN and consequent toll charges.

The PBX-IP media gateway has quite a different function. It is an IP-enablement tool that allows IP technology to be introduced easily and gradually into a legacy environment at the pace that the enterprise finds most cost-effective for its workload and current infrastructure.

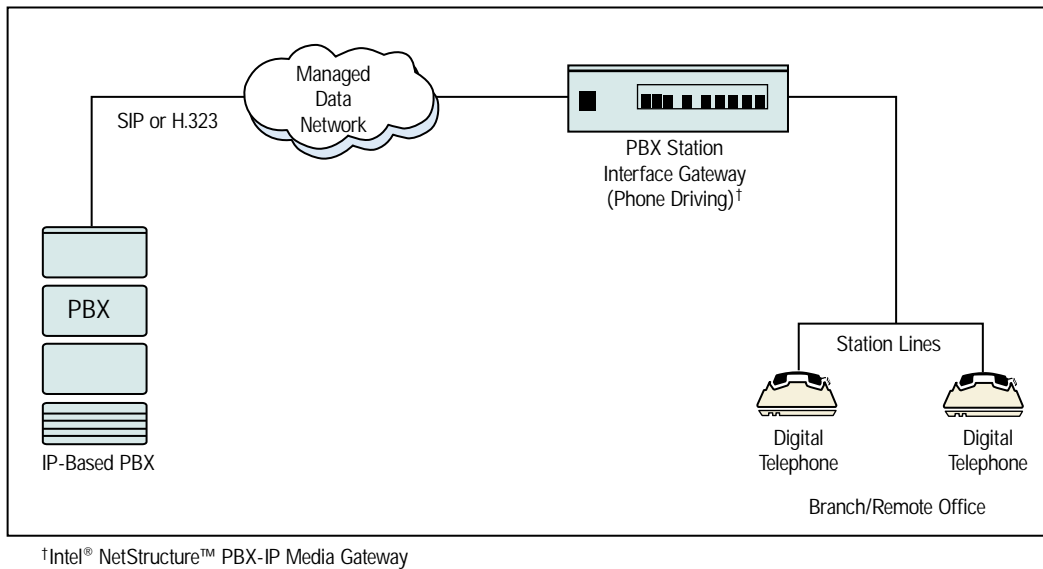

Figure 5. Connecting Legacy Phones to an IP-PBX

Scenario 2: Connecting Legacy Phones to an IP-PBX

Just as IP phones can be used with a circuit-switched PBX because of the PBX-IP media gateway, legacy phone sets can be used with an IP-PBX with the PBX-IP media gateway. See Figure 5 for an illustration.

Scenario 2 is very common in market segments such as retail. Retailers often have digital phones installed throughout their stores, but need to migrate to an IP-PBX for new applications to remain competitive. The PBX-IP media gateway allows retailers to install an

IP-PBX, but continue to use their legacy phones without rewiring each of their stores. However, all types of organizations can use the PBX-IP media gateway as shown in Figure 5 if they wish to install an IP-based PBX and want to preserve their investment in legacy phone equipment.

Scenario 1 is an example of an emulating PBX-IP media gateway. Scenario 2 is an example of a different model called a phone-driving unit.

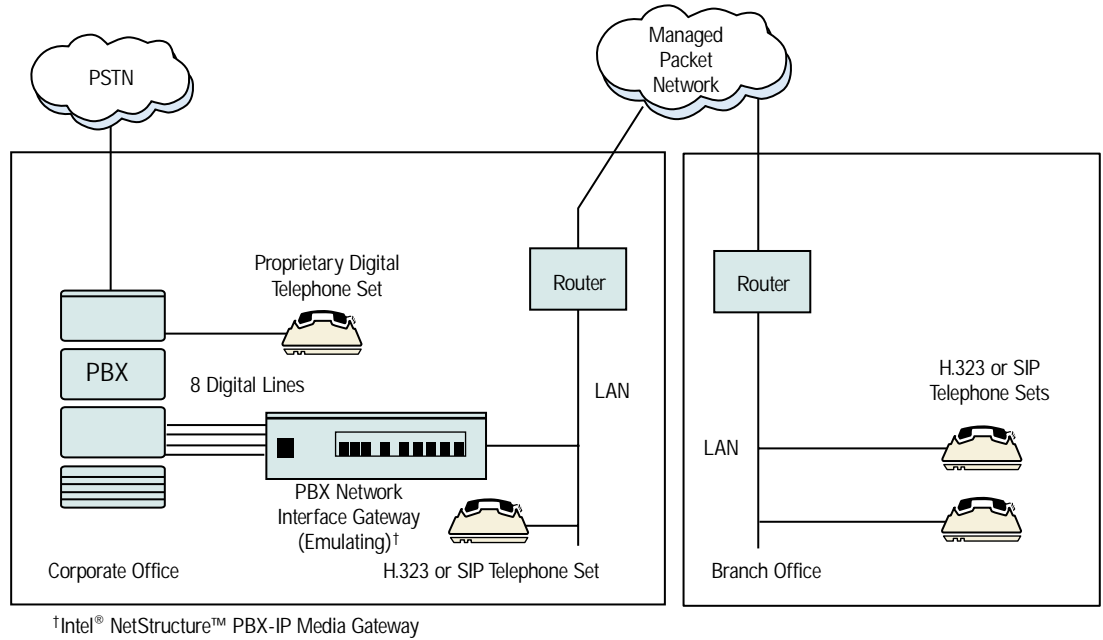

Figure 6. Connecting to IP Phones at a Remote Site

Scenario 3: Connecting to a Remote Office Using IP

In scenario 3, the PBX-IP media gateway is used to connect a circuit-switched PBX to H.323 or SIP phones in two or more locations:

- At a **main site** using the enterprise LAN
- At a **remote site** using the remote office LAN across the enterprise’s managed packet network

Using the PBX-IP media gateway in this type of scenario can provide the following benefits:

- Increases flexibility by allowing IP phones and legacy phones to be used interchangeably to place local or remote calls using both IP-based and PBX networks

- Reduces the costs of calls between the main office and remote sites significantly by using an existing WAN
- Deploys quickly because no PBX software needs to be upgraded
- Protects investment because legacy phones can continue to be used
- Saves on equipment costs because remote sites may not require their own PBXs

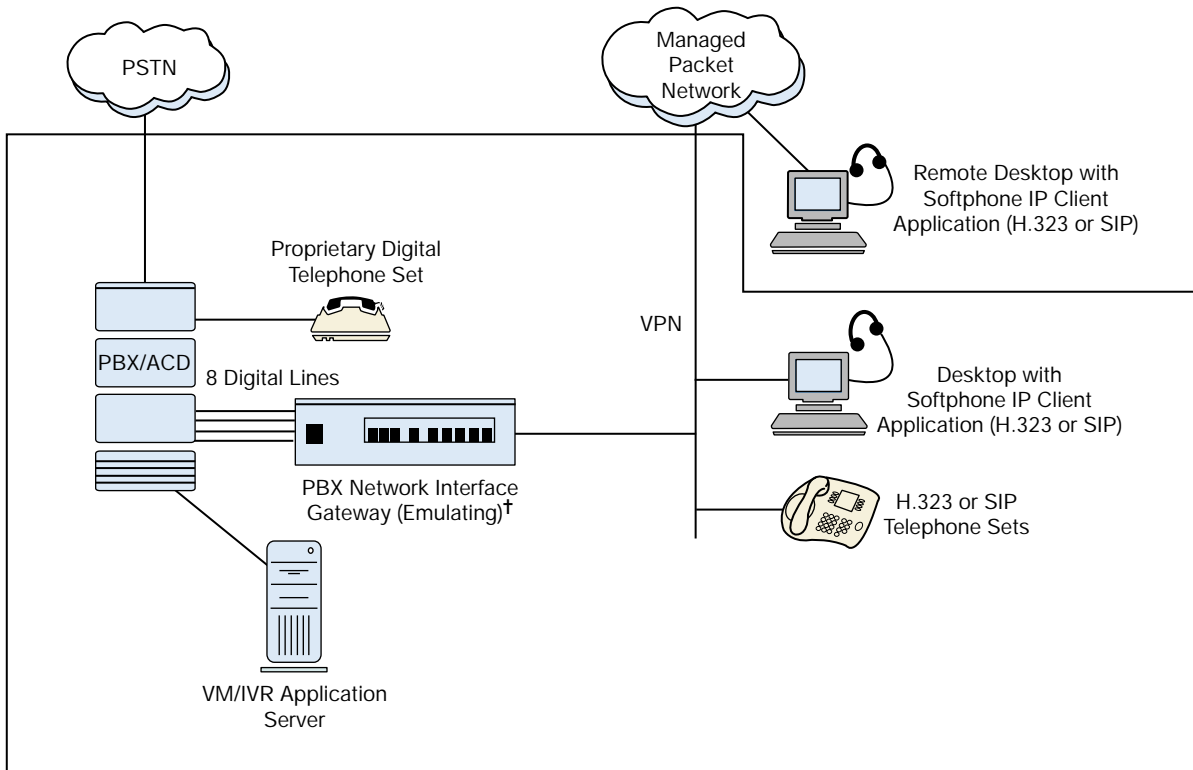

†Intel® NetStructure™ PBX-IP Media Gateway

Figure 7. Connecting Remote Workers

Scenario 4: Telecommuting

Scenario 4 demonstrates how the PBX-IP media gateway can provide a cost-effective solution for connecting telecommuters to an existing PBX environment.

Whether remote workers are at an office at home or a customer site, they can receive voice and data through the same VPN connection while enjoying access similar to that of workers in the enterprise's main location.

Workers can simultaneously browse corporate data and speak with customers or each other. Because the PBX-IP media gateway works with the existing network and PBX equipment, packetized technology integrates seamlessly with the current system and IP softphone applications.

In this scenario, an emulating PBX-IP media gateway is connected to a legacy PBX through its digital line card. The PBX may also be connected to adjunct applications such as voice mail (VM) and interactive voice response (IVR).

The gateway is also connected to a LAN or WAN via a 10/100BaseT Ethernet connection. The user connects to corporate headquarters through a broadband VPN connection and accesses PBX features using either a softphone client running on a PC or an IP telephone.

Calls can be placed and received on any telephone using the VPN connection to carry voice and the PBX-IP media gateway to bridge the gap between the IP network or the PBX network.

Using this configuration can enable several key features for a telecommuter including:

- One-number access because anyone who calls the telecommuter's office number generates an IP call to the telecommuter's softphone
- Message waiting indication so that telecommuters know if their corporate voice mail boxes contain any messages without having to constantly call to check (This feature may require additional voice mail configuration)

- Use of corporate PBX to make outbound calls, thereby eliminating the hassle of submitting expense reports to be reimbursed for calls made from home
- Ability to contact anyone at the corporate office by using a three- or four-digit PBX extension

Conclusion

The PBX-IP media gateway is a standalone device that converts PBX messages into Internet Protocol (IP) for transmission over a managed packet network. The gateway provides access to applications running on networked servers and extends PBX functionality to H.323 and SIP devices locally or remotely and to softphone client applications.

In essence, the gateway is the bridge between a legacy PBX and the managed packet network. It offers eight ports of digital PBX or digital phone connectivity.

Enterprises interested in providing IP solutions and creating new applications without having to worry about system integration will find that the PBX-IP media gateway offers a simplified, cost-effective way to converge voice and data across a managed packet network while preserving legacy PBX investment and allowing migration to IP technology at a controlled pace.

More Information and Additional Services

Additional information about the Intel NetStructure PBX-IP media gateway, including ordering information, is available at <http://www.intel.com/network/csp/products/7135web.htm>.

Practical Telecommuting Solutions, a related white paper, can be found at <http://www.intel.com/network/csp/pdf/8141.htm>.

Intel also offers consulting, education, and support through Intel® Net Services. You can find a description of these services at <http://www.intel.com/design/network/products/telecom/services/index.htm>.

To learn more, visit our site on the World Wide Web at <http://www.intel.com>.

1515 Route Ten
Parsippany, NJ 07054
Phone: 1-973-993-3000

INFORMATION IN THIS DOCUMENT IS PROVIDED IN CONNECTION WITH INTEL® PRODUCTS. NO LICENSE, EXPRESS OR IMPLIED, BY ESTOPPEL OR OTHERWISE, TO ANY INTELLECTUAL PROPERTY RIGHTS IS GRANTED BY THIS DOCUMENT. EXCEPT AS PROVIDED IN INTEL'S TERMS AND CONDITIONS OF SALE FOR SUCH PRODUCTS, INTEL ASSUMES NO LIABILITY WHATSOEVER, AND INTEL DISCLAIMS ANY EXPRESS OR IMPLIED WARRANTY, RELATING TO SALE AND/OR USE OF INTEL PRODUCTS INCLUDING LIABILITY OR WARRANTIES RELATING TO FITNESS FOR A PARTICULAR PURPOSE, MERCHANTABILITY, OR INFRINGEMENT OF ANY PATENT, COPYRIGHT OR OTHER INTELLECTUAL PROPERTY RIGHT. Intel products are not intended for use in medical, life saving, life sustaining applications.

Intel may make changes to specifications and product descriptions at any time, without notice.

** Performance tests and ratings are measured using specific computer systems and/or components and reflect the approximate performance of Intel products as measured by those tests. Any difference in system hardware or software design or configuration may affect actual performance. Buyers should consult other sources of information to evaluate the performance of systems or components they are considering purchasing. For more information on performance tests and on the performance of Intel products, reference <http://www.intel.com/procs/perf/limits.htm> or call (U.S.) 1-800-628-8686 or 1-916-356-3104.

Intel, Intel NetStructure, and the Intel logo are trademarks or registered trademarks of Intel Corporation or its subsidiaries in the United States and other countries. The Intel logo is a registered trademark of Intel Corporation.

*Other names and brands may be claimed as the property of others.

